

ORDINANCE 2018-_____

AN ORDINANCE OF THE BOARD OF COUNTY COMMISSIONERS OF NASSAU COUNTY, FLORIDA AMENDING SECTION 37.05 OF THE LAND DEVELOPMENT CODE, LANDSCAPING; AMENDING THE SUPPLEMENTAL TREE LIST FOR LANDSCAPING; PROVIDING FOR ALTERNATIVE TREE SPECIES PLANTING ADJACENT TO UTILITIES; PROVIDING FOR BUFFER PLANTING DETAIL; AMENDING PLANTING REQUIREMENTS; PROVIDING FOR CLARITY IN THE RELATIONSHIP BETWEEN BUFFERS, UTILITIES AND FENCING; PROVIDING FOR PURPOSE AND INTENT; PROVIDING FOR SEVERABILITY; PROVIDING FOR CODIFICATION; AND PROVIDING AN EFFECTIVE DATE.

WHEREAS, Nassau County adopted the Natural Resources Protection Ordinance, 2008-01, which included Article 37.05 of the Land Development Code; and

WHEREAS, Article 37.05 outlines minimum landscape requirements for the unincorporated areas of Nassau County and recognizes the need for minimum standards for the design, plant selection, installation and maintenance of landscape elements and site improvements; and

WHEREAS, Understanding the importance of analyzing the applicable effectiveness of Ordinance 2008-01, the Planning and Zoning Board finds that additional changes need to be made to the Article 37.05 of the Land Development Code; and

WHEREAS, Staff has recommended certain amendments to Article 37.05 (landscaping) of the Land Development Code to the Planning and Zoning Board; and

WHEREAS, the Planning and Zoning Board conducted a public hearing on this Ordinance on _____ 2018 and voted to recommend approval and legal notice of this Ordinance has been provided in accordance with Sec. 125.66, F.S.

NOW, THEREFORE, BE IT ORDAINED BY THE BOARD OF COUNTY COMMISSIONERS OF NASSAU COUNTY, FLORIDA:

SECTION 1. FINDINGS

This Ordinance is consistent with the Nassau County Comprehensive Plan, in particular Policies FL.03.02 and CS.06.02.

SECTION 2. AMENDMENT

Section 37.05. - Landscaping.

A. *Applicability.*

1. The standards established in this section are to be considered the minimum requirements for the design, plant selection, installation and maintenance of landscape elements and site improvements and shall apply to all new development.
2. Developments constructed under previously effective landscaping requirements are not required to comply with this section. However, the requirements of this section shall also apply to the redevelopment, reconfiguration, expansion or change of use of a previously developed site, unless such change falls below the following threshold:

- a. The existing developed impervious area is seven thousand five hundred (7,500) square feet or less, and the proposed expansion of impervious surface is seven hundred fifty (750) square feet or less.
 - b. The existing developed impervious area is greater than seven thousand five hundred (7,500) square feet, and the proposed expansion of impervious surface is less than two thousand (2,000) square feet, and also less than ten (10) percent of the existing impervious area on the parcel or lot.
3. Partial exemption. Developments that have received site plan approval or construction plan approval prior to the effective date of this ordinance are subject only to the minimum tree planting by use, subsection 37.05(C) LDC.
- B. *Plant material*. All installed trees, shrubs and groundcovers shall conform to the standards for Florida Grade #1 or better according to the current edition of "Grades and Standards for Nursery plants" published by the Florida Department of Agriculture and Consumer Services, Division of Plant Industry. Synthetic or artificial trees, shrubs, groundcovers or vines are not acceptable substitutes. In choosing plant materials, consideration should be given to the amount of sun or shade, the wetness or dryness of the soil, the effects of salt spray (where applicable), the amount of irrigation required and the mature size and spatial needs of plants chosen.
- 1. The minimum number of trees required by this section shall be either qualifying existing trees preserved on-site or more than one species listed in Tables 37-1 or 37-2. Trees planted in addition to these minimum requirements of this section may be any species of canopy tree or palm except for the prohibited species listed herein. In order to prevent a monoculture, new landscaping should not include more than fifty (50) percent of any one genus or twenty-five (25) percent of any one species. All trees shall be planted in a minimum dimension of ten (10) feet. This minimum planting area must be free of all pavement and vehicle overhang in order to prevent possible tree damage. All trees shall have a minimum trunk diameter, measured six (6) inches above ground level, in accordance with Table 37-3.
 - 2. Shrubs shall have a minimum height of eighteen (18) inches when planted. When planted as a hedge, the maximum spacing is 30 inches on center. All shrubs used for visual screening shall be of a plant species that is capable of reaching a height of four (4) feet within twenty-four (24) months under normal growing conditions. Shrubs used as accent ground cover and vines may vary in size depending on the type of plant material and the desired effect.
 - 3. Groundcovers shall be planted in such manner as to present a finished appearance and complete coverage within one (1) year after planting.

Name	Common Name	Mature Height (ft.)	Rate of Growth	Salt Tolerance	Drought Tolerance
Acer rubrum	Red Maple	35—50	Fast	Low	Med
Betula nigra	River Birch	45—65	Fast	Low	Low

Bumelia spp	Buckthorn	20—40	Med	M/L	M/High
Carpinus caroliniana	American hornbeam	25—35	Slow	Low	Low
Carya glabra	Pignut hickory	80—120	Fast	Low	High
Cercis canadensis	Redbud	20—30	Med	Low	High
Cornus florida	Flowering dogwood	20—30	Med	Low	High
Diospyros virginiana	Persimmon	30—60	Med	Low	Med
Fagus grandifolia	American Beech	50—100	Slow	Med	Med
Ilex attenuata	East Palatka Holly	30—45	Med	Med	High
Ilex cassine	Dahoon Holly	25—40	Med	Med	Med
Ilex opaca	American Holly	30—45	Slow	Med	Med
Juniperus silicicola	Southern Red Cedar	25—30	Med	High	High
Juniperus virginiana	Eastern Red Cedar	10—40	Slow	Med	Med
Liquidambar styraciflua	Sweetgum	60—100	Fast	Med	High
Liriodendron tulipifera	Tulip Tree/Yellow Poplar	80—100	Fast	Low	Low
Magnolia grandiflora	Southern Magnolia	60—100	Med	High	High
Magnolia virginiana	Magnolia/Sweetbay	40—60	Med	Low	Low
Nyssa sylvatica	Black Tupelo	50—80	Med	Low	Low
Ostrya virginiana	Eastern Hophorn beam	20—40	Med	Low	High
Quercus alba	White Oak	50—80	Med	High	Med
Quercus austrina	Bluff Oak	25—40	Med	Low	Low
Quercus chapmanii	Chapman Oak	30-45	Slow	Med	High
Quercus laurifolia	Laurel Oak	60—100	Fast	Low	High
Quercus shumardii	Shumard Oak	40—60	Slow	Low	Med
Quercus myrtifolia	Myrtle Oak	10—25	Slow	Med	High
Quercus virginiana	Live Oak	50—60	Med	High	High
Taxodium distichum	Bald Cypress	60—100	Med	Med	High
Tilia floridana	Florida Basswood	30—60	Fast	Low	Low
Ulmus alata	Winged elm	20—40	Med	Low	High
Ulmus americana	American Elm	80—100	Fast	Low	Med

Table 37-2. Supplemental Tree List for Landscaping

Name	Common Name	Mature Height (ft.)
Pyrus Calleryana	Bradford pear	34—40
Ulmus parvifolia	Chinese elm	40—50
Magnolia Soulangeriana	Saucer magnolia	20—30
Carya illinoensis	Pecan	70—100

Quercus michauxii	Swamp chestnut oak	60—70
Ilex attenuata	East Palatka holly	30—45
Ilex attenuata	Savannah holly	30—45
Ilex cornuta	Chinese holly	20—30
Taxodium ascendens	Pond cypress	60—100
Quercus nuttallii	Nuttall oak	50—80
Salix Babylonica	Weeping willow	25—30
Myrica Cerifera	Wax myrtle	20—30
Persea Borbonia	Red bay	30—40
Plantanus occidentalis	Sycamore	70—150
Table 37-3. Minimum Tree Caliper at the Time of Planting		
Existing tree replacement		3 inches
Multi-family and non-residential <u>All other plantings except below</u>		3 inches
Individual single family lots/homes and community facilities		2 inches

Table 37-4[A] Amelia Island Protected Native Canopy Trees					
Name	Common Name	Mature Height (ft.)	Rate of Growth	Salt Tolerance	Drought Tolerance
Acer rubrum	Red Maple	35—50	Fast	Low	Med
Betula nigra	River Birch	45—65	Fast	Low	Low
Fraxinus spp.	Ash	60—80	Med	Med	Med
Carya spp.	Hickory	80—120	Fast	Low	High
Celtis laevigata	Sugarberry/ Sugar hackberry	80—100	Fast	High	High
Diospyros virginiana	Persimmon	30—60	Med	Low	Med
Prunus spp.	Cherry	30—60	Med	Low	Med
Ilex opaca	American Holly	30—45	Slow	Med	Med

Juniperus silicicola	Southern Red Cedar	25—30	Med	High	High
Juniperus virginiana	Eastern Red Cedar	10—40	Slow	Med	Med
Liquidambar styraciflua	Sweetgum	60—100	Fast	Med	High
Liriodendron tulipifera	Tulip Tree/Yellow Poplar	80—100	Fast	Low	Low
Magnolia grandiflora	Southern Magnolia	60—100	Med	High	High
Magnolia virginiana	Magnolia/Sweetbay	40—60	Med	Low	Low
Nyssaslyvatica	Black Tupelo/Black Gum	50—80	Med	Low	Low
Quercus alba	White Oak	50—80	Med	High	Med
Quercus laurifolia	Laurel Oak	60—100	Fast	Low	High
Quercus shumardii	Shumard Oak	40—60	Slow	Low	Med
Quercus virginiana	Live Oak	50—60	Med	High	High
Taxodium distichum	Bald Cypress	60—100	Med	Med	High
Ulmus americana	American Elm	80—100	Fast	Low	Med

Table 37-4 Understory Trees

<u>Cornus florida</u>	<u>Flowering Dogwood</u>
<u>Chionanthus virginicus</u>	<u>White Fringetree</u>
<u>Magnolia x saulangeana</u>	<u>Saucer Magnolia</u>

<u>Prunus angustifolia</u>	<u>Chickasaw Plum</u>
<u>Ilex cassine</u>	<u>Dahoon Holly</u>
<u>Ilex attenuata</u>	<u>East Palatka Holly</u>
<u>Lagerstroemia spp.</u>	<u>Crape Myrtle</u>
<u>Juniperus chinensis</u>	<u>Chinese Juniper</u>
<u>Calistemon spp.</u>	<u>Bottlebrush</u>
<u>Gordonia lasianthus</u>	<u>Loblolly Bay</u>

All trees planted shall be staked or guyed for a period of at least six (6) months in accordance with the following planting detail:

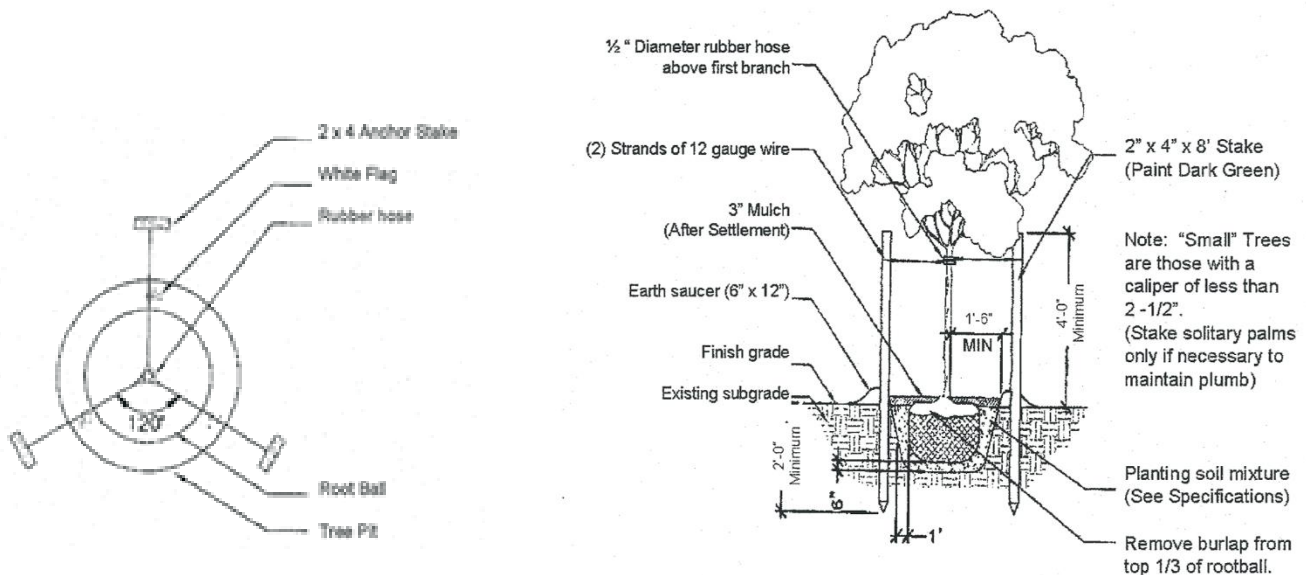

Planting Detail

C. *Minimum tree planting requirements by use.*

1. *One and two-family dwellings.* Each single family and two-family lot must provide at least one (1) tree per three thousand (3,000) square feet of lot area for the first quarter acre of lot area. For lots exceeding one-quarter (1/4) acre, one (1) tree for every additional one-quarter (1/4) acre, or major fraction thereof, must be preserved or planted. Existing canopy trees, sabal palms and pine trees may be used to satisfy this requirement, in whole or in part, provided that they have a minimum caliper of four (4) inches DBH. When trees are planted to meet the minimum requirement they must be more than one species of tree listed in Tables 37-1 or 37-2 and meeting the material standards of this section. The foregoing represent the entire requirement applicable to individual one and two-family dwellings.
2. *Multi-family, mobile home park and travel trailer parks.* In addition to the use buffer and perimeter landscaping adjacent to a right-of-way requirements found in this Section, each multi-family, mobile home park and travel trailer park must plant or preserve an additional one tree for every two (2) dwelling units. When trees are planted to meet the minimum requirement they must be more than one species of tree listed in Tables 37-1 or 37-2 and meeting the material standards of this section.

3. *Non-residential developments.* In addition to the buffer and perimeter landscaping adjacent to a right-of-way requirements found in this section, each commercial and/or industrial development must provide a minimum of ten (10) percent of the lot or parcel as pervious green space planted with one or more species of tree listed in Tables 37-1 or 37-2 for every five hundred (500) square feet of such green space.

D. *Perimeter landscaping adjacent to public rights-of-ways and streets:* Except for individual one and two family dwellings, all developments located along a public or private right-of-way or street shall be required to provide the following perimeter landscaping. Perimeter landscaping adjacent to rights-of-ways/streets and required screening of vehicle use areas as considered in this section and those uncomplimentary use buffers defined in Section 37.06 LDC are required to be designed, through material selection and arrangement, in such a manner as to create depth in the planting area and increase visual interest through staggered heights. The illustrations provided in this Article are for explanatory purposes. Natural areas which contain significant growth that serve the functional purpose of providing depth and variations in height may supplement new plantings in part or whole depending upon the quality of natural vegetation. The use of a wall or fence is permitted provided the wall or fence is located on the inner most boundary (behind the vegetation as viewed from outside the development) of the perimeter landscaping adjacent to rights-of-ways/streets, required buffer or other landscaped area.

Planting Elevation Example

A Perimeter Bed planting plan can mass plant material of varying heights and widths within the planting bed in order to add interest when viewed from all sides.



Figure credit: Sue Ann Alleger, Nassau County, FL Dept. of Planning and Economic Opportunity

1. *A1A/S.R. 200, U.S. Highway 1 and U.S. 301.* A strip of pervious land adjacent and parallel to the right-of-way line having an average width of twenty-five (25) feet and a minimum width of ten feet along the entire street frontage except for permitted driveways. This perimeter landscaping strip shall contain a minimum of three (3) canopy trees per one hundred (100) linear feet of property frontage and three (3) understory trees per one hundred (100) linear feet of property frontage. The canopy trees shall consist of more than one species listed in Tables 37-1 or 37-2 and meeting the material standards of this section. Planted trees are not meant to be spaced evenly but rather randomly distributed by species.

If the required perimeter landscape is left undisturbed (except for authorized driveways and utilities), credit shall also be given for the preservation of pine and palm trees having a minimum 8-inch dbh. Undisturbed shall mean there is no grade change or other disturbance within ten (10) feet of a pine and five (5) feet of a palm. Understory clearing shall be by hand tools only.

The area between preserved and planted trees can be supplemented with native or naturalized shrubs to provide required screening adjacent to parking areas.

A1A/SR17/US 301

Buffer Planting Bed Requirements and Planting Design Suggestions

Requirements Three (3) Canopy Trees every 100 feet and three (3) Understory Trees every 100 feet

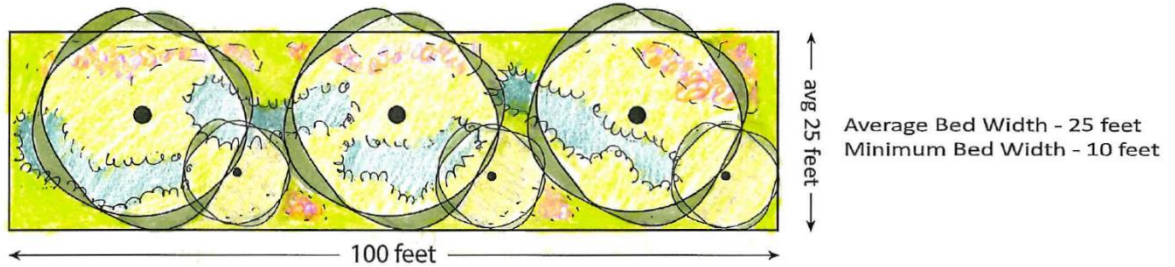

Suggestions It is not the intention of these examples to limit design expression but to provide non-symmetrical planting plan suggestions in order to encourage variety and interest in perimeter buffer plantings.

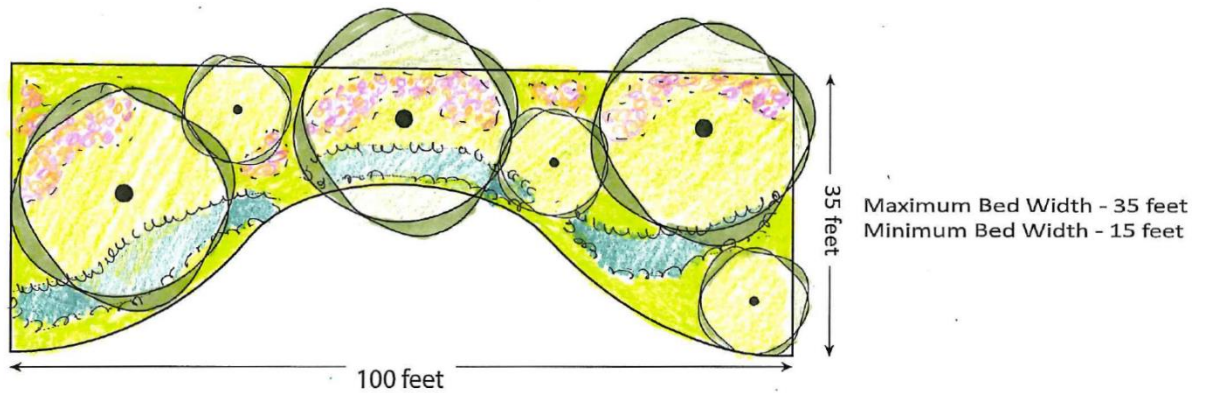
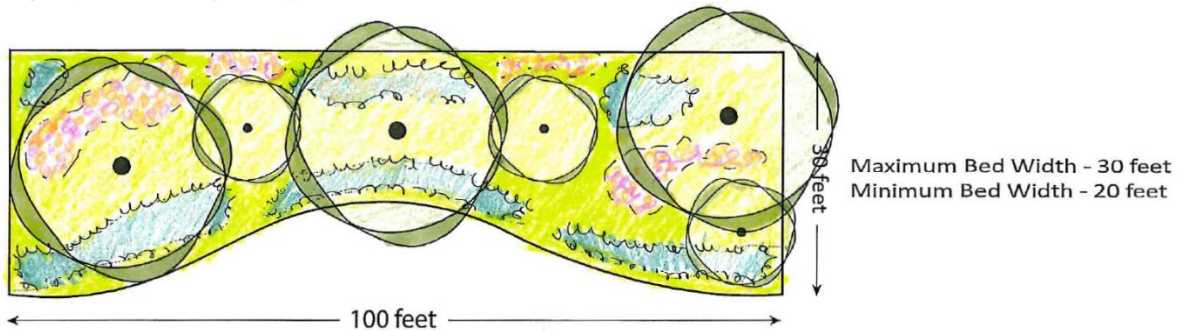

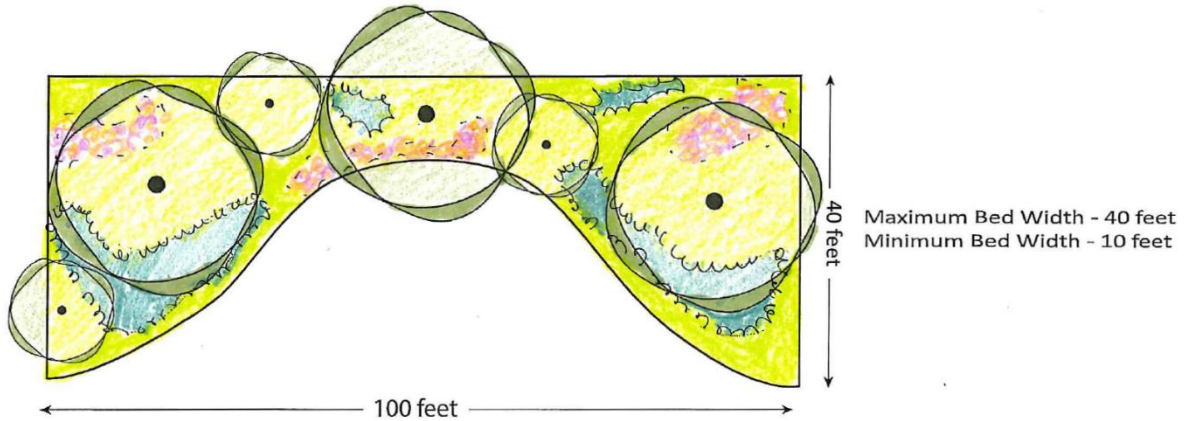
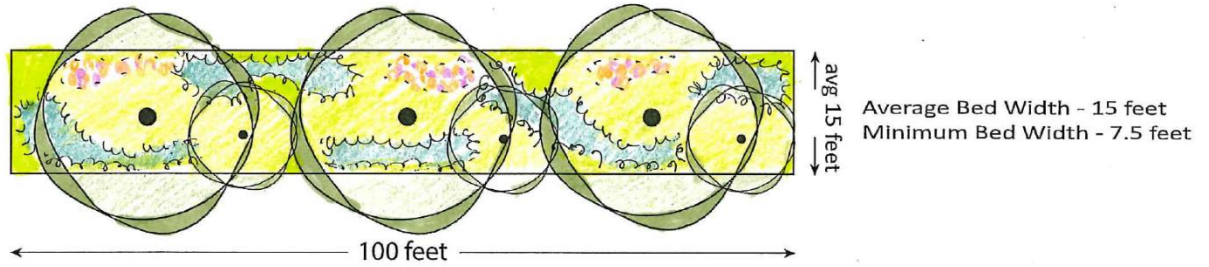

Figure credit: Sue Ann Alleger, Nassau County, FL Dept. of Planning and Economic Opportunity

2. *Other arterial and collector roadways.* All other arterial and collector roadways, as identified by the comprehensive plan, shall provide a strip of pervious land adjacent and parallel to the right-of-way line having an average width of fifteen (15) feet and a minimum width of seven and one-half (7½) feet along the entire street frontage except for permitted driveways. This perimeter landscaping strip shall contain a minimum of three (3) canopy trees per one hundred (100) linear feet of property frontage and three (3) understory trees per one hundred (100) linear feet of property frontage. The canopy trees shall consist of more than one species listed in Tables 37-1 or 37-2 and meeting the material standards of this section. Planted trees are not meant to be spaced evenly but rather randomly distributed by species within the largest open spaces.

Arterial and Collector Roadways
Buffer Planting Bed Requirements and Planting Design Suggestions

Requirements Three (3) Canopy Trees every 100 feet and three (3) Understory Trees every 100 feet



Suggestions It is not the intention of these examples to limit design expression but to provide non-symmetrical planting plan suggestions in order to encourage variety and interest in perimeter buffer plantings.

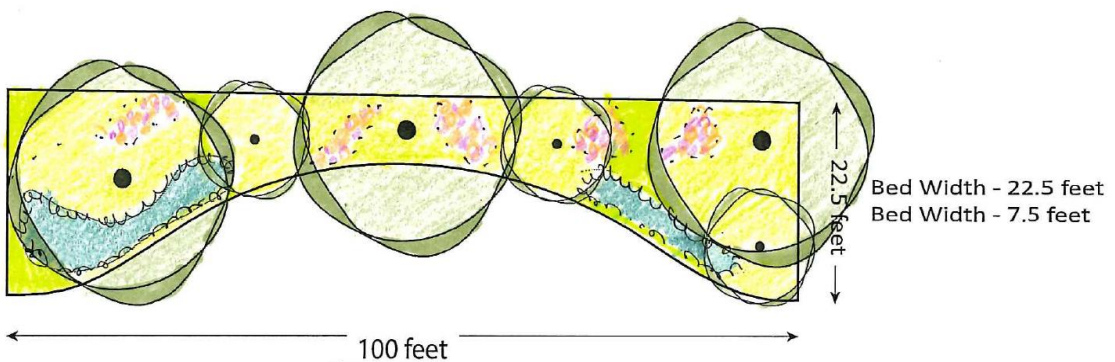
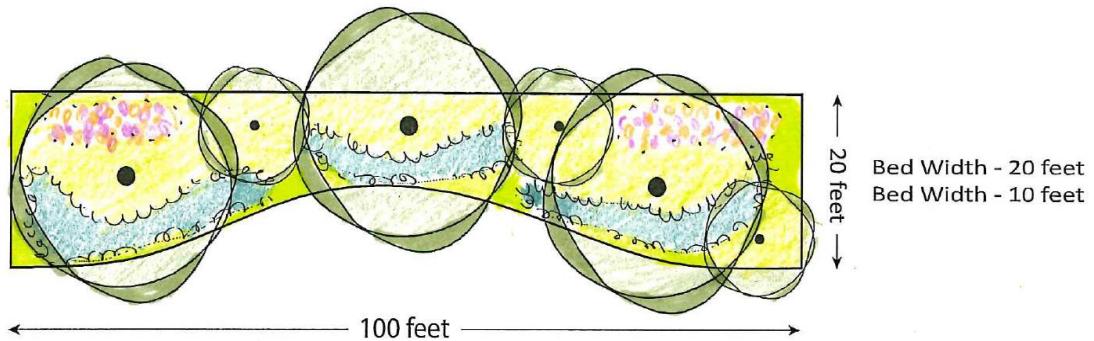

Figure credit: Sue Ann Alleger, Nassau County, FL Dept. of Planning and Economic Opportunity

3. **Local streets.** A strip of pervious land adjacent and parallel to the right-of-way street line having a minimum width of ten (10) feet along the entire street frontage except for permitted driveways. This perimeter landscaping strip shall contain a minimum of two (2) canopy trees per one hundred (100) linear feet of property frontage and three (3) understory trees per one hundred (100) linear feet of property frontage. The canopy trees shall consist of more than one species listed in Tables 37-1 or 37-2 and meeting the material standards of this section.

Local Streets

Buffer Planting Bed Requirements and Planting Design Suggestions

Requirements Two (2) Canopy Trees every 100 feet and three (3) Understory Trees every 100 feet

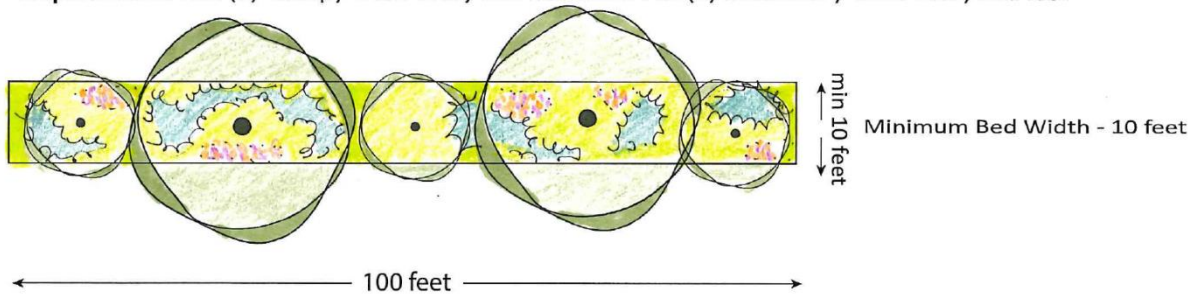

Suggestions It is not the intention of these examples to limit design expression but to provide non-symmetrical planting plan suggestions in order to encourage variety and interest in perimeter buffer plantings.

Figure credit: Sue Ann Alleger, Nassau County, FL Dept. of Planning and Economic Opportunity

4. Sidewalks. Sidewalks or multi-use trail may be incorporated within an easement located within a perimeter landscaping strip if the average width is increased by ~~five (5) feet~~ the width of the sidewalk or trail above the minimum required width and if the sidewalk meanders around existing trees or is incorporated into the landscape design.
5. Required screening. Except for one and two-family dwellings, all off-street parking areas, drive aisles, and paved storage areas lying within fifty (50) feet of, and visible from any street right-of-way, the perimeter landscaping requirement of this section shall also include shrubs planted as a hedge meeting the requirements of Sec. 37.05.B.2 LDC. ~~arranged to provide a visual screen of seventy five (75) percent opacity and achieve a minimum height of three (3) feet within three (3) years of planting.~~
6. Dumpsters and mechanical equipment (as permitted by the underlying zoning designation) shall be screened through the use of a wall, which is one hundred (100) percent opaque in conjunction with landscaping. Minimum landscaping shall include one (1) shrub every two (2) feet. The shrub shall be maintained at a minimum of four (4) feet in height. One (1) canopy tree or understory tree per ten (10) linear feet of wall or fence unless said fence or wall is less than eight (8) feet in length.
7. Use of understory trees (ref. Table 37-4 LDC) are permitted in lieu of native canopy trees listed in Table 37-1 and 37-2 as determined to be practical by the Director of Planning and Economic Opportunity or designee because of overhead utility lines or other overhead restrictions that cannot otherwise be mitigated through design modifications. Financial impacts related to design modifications necessary to avoid utilities will not be considered. Understory trees may be permitted at a rate of one (1) tree for every 15 feet of site/lot frontage along the right-of-way or street. Preserved or retained trees on-site located within the perimeter landscape strip defined in Section 37.05.D LDC shall count towards satisfying this requirement provided the trees are healthy, as determined by an ISA certified arborist, are listed in tables 37-1, 37-2 or 37-4, and do not interfere with existing or planned utilities. At the time of planting, Crape Myrtles shall be a minimum of eight (8) feet in height and measure three (3) caliper inches if a single trunk or an aggregate of six (6) inches if a multi-trunk.
8. Perimeter landscape strips required by this section shall not be encumbered by a utility easement, unless 1) the utilities are located underground; 2) will not prevent trees from reaching maturity; and, 3) approval for tree planting is granted by the utility provider in writing, on utility provider letterhead, to Nassau County. The perimeter landscape strip required by this section shall not include any portion of a stormwater management facility, borrow-pit, fishing pond or similar excavation.

9. For one and two family residential developments where all Lots/building sites measure five acres in area or greater and have a minimum of 100' of frontage on a street, the required perimeter landscape strip adjacent to a street or right-of-way may be included within the Lot/building site. The installation of plant material may take place with the construction of the home on that particular Lot/building site. For all other cases, the perimeter landscape strip adjacent to a street or ROW shall be in a separate tract of land under the control of the Home Owners Association, or equivalent, and not included within a Lot/building site.

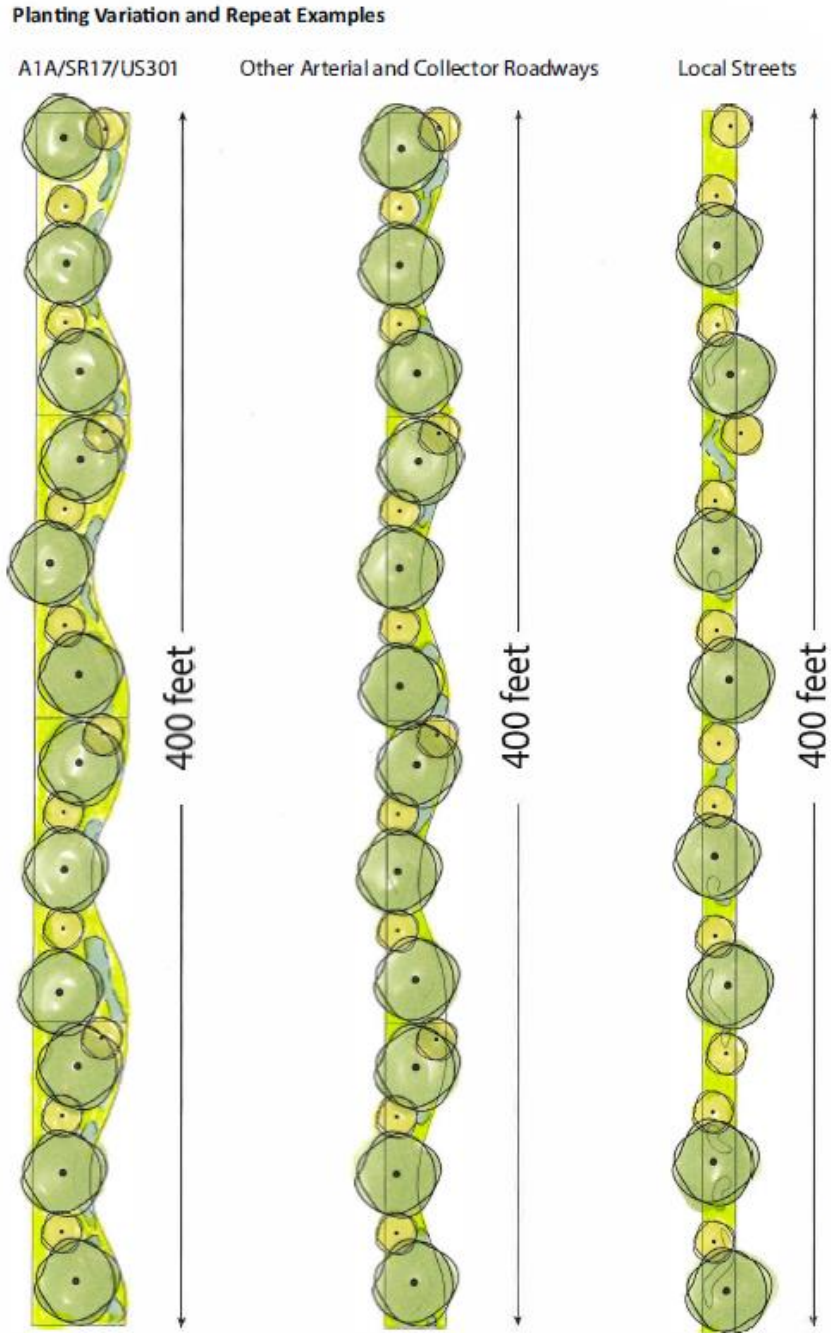

Figure credit: Sue Ann Alleger, Nassau County, FL Dept. of Planning and Economic Opportunity

E. *Intersection sight distance clearance:*

1. At the intersection of two (2) streets, all landscaping within that area defined by the Florida Department of Transportation sight triangle, as outlined in the *FDOT Design Standards for Design, Construction, Maintenance and Utility Operations on the State Highway System* shall be installed and maintained below three feet in height or above eight feet in height.
2. When a driveway intersects a right-of-way, clear unobstructed cross visibility shall be provided within the site triangle formed by such intersection. The sight triangle shall be measured from the point of intersection, fifteen (15) feet along the access way and then fifteen (15) feet along the right-of-way, with the third side being a line connecting the two (2) points. Cross visibility within the sight triangle shall be unobstructed between the height of three (3) feet and eight (8) feet measured from the ground line. Trees and palms shall have their limbs and foliage trimmed in a manner that no limbs or foliage will extend in to the cross visibility area. To ensure proper visibility at the intersection of access ways with public right-of-ways, excluding properly trimmed trees as previously stated; only ground cover type plants shall be allowed within the sight triangle.

F. *Interior landscaping regulations:*

1. Except for one and two-family dwellings, all off-street parking areas shall contain interior landscaping islands at a ratio of one (1) island for each ten (10) parking spaces. Rows of parking spaces abutting a sidewalk adjacent to a building are exempt from required landscape islands except for terminal islands at the end of each row. Such landscaped areas are creditable to the minimum landscape requirements for multi-family, mobile home park, travel trailer park and non-residential developments.
2. Each separate interior landscaped island shall contain a minimum of one hundred sixty-six (166) square feet and shall be at least ten (10) feet wide as measured from back of curb. A minimum of one (1) canopy tree shall be planted in each interior landscaping island with the remaining area adequately planted with shrubs, ground cover, or other approved landscaping materials.
3. All interior landscaping shall be protected from vehicle encroachment by curbing or wheel stops.
4. Interior landscaping shall be located in a manner, which will divide or interrupt the broad expanse of paving. Landscaped areas shall subdivide rows of parking spaces into a maximum of ten (10) consecutive spaces. Each group of ten (10) shall have terminal islands at each end. This maximum may be adjusted to provide for the preservation of existing canopy trees.

G. *Xeriscape.* Xeriscaping (waterwise) is landscaping that conserves water and protects the environment and is adaptable to local conditions and which are drought tolerant. Xeriscape techniques maximize the conservation of water use with site appropriate plants, an efficient watering system, proper planning and design, soil analysis, practical use of turf, the use of mulches (which may include the use of solid waste compost) and proper maintenance. The following water efficient principles should be applied to the landscape plan:

1. All plantings shall be grouped in zones according to water requirements and shall be irrigated in zones separating high water use areas from drought tolerant zones. The zones are as follows:
 - a. *High water use zone:* A zone containing plants which are associated with moist soils and require supplemental water in addition to natural rainfall to survive. This zone includes most turf grasses.
 - b. *Moderate water use zone:* A zone containing plants which survive on natural rainfall with supplemental water during seasonal dry periods.

- c. *Low water use zone*: A zone containing plants which survive on natural rainfall without supplemental water.
 - 2. Fifty (50) percent of the plants used in all vehicular use area landscape designs should be drought tolerant and located in groupings according to zones designated by the water requirements.
 - 3. Turf grass areas should be consolidated and limited to those areas on the site that receive pedestrian traffic, provide for recreational uses, provide soil erosion control such as berms, slopes and swales, where turf grass is used as a design unifier or other similar practical use.
 - 4. All planting areas shall be mulched with approximately three (3) inches of organic mulch, such as pine bark or shredded hardwood chips.
- H. *Firewise*. Landscape within the wildlife/urban interface are subject to wildfire hazard and should incorporate Firewise landscaping techniques. Such techniques include:
- 1. Creating a defensible space zone around buildings. Such zones shall provide space for fire suppression equipment in the event of an emergency and progressively limit plantings near structures to carefully spaced fire resistant species.
 - 2. Placing low growing species and groundcovers beneath canopy trees and rooflines to avoid creating a continuous fuel source from ground to tree or roof.
 - 3. Utilizing driveways, lawn areas and walkways to provide firebreaks between large areas of dense vegetation.
 - 4. Selective thinning of fire prone plant species in existing vegetation areas to reduce fuel loads. A list of fire prone species is available from the Division of Forestry.
- I. *Prohibited trees*. Any species identified on the most recent Florida Exotic Pest Plant Council Invasive Plant list (Category I or II) is ~~The following tree species are~~ expressly forbidden from being planted or used as required or supplemental landscaping material. Invasive non-native vegetation in general is a public nuisance that degrades landscaped and natural areas. ~~On a case by case basis, the county may provide credit against required landscaping if existing stands of mature prohibited trees are completely removed.~~
- J. *Maintenance*. The property owner is responsible for the maintenance of all landscape areas required by this section. Maintenance includes irrigating, mowing, trimming, fertilizing and carrying out those activities necessary to keep the plant material in a healthy and growing condition, maintain visual clearance and allow passage of vehicles and pedestrians on public roads and non-exclusive easements.
- 1. Upon determination by the county that a required tree or plant is dead or severely damaged or diseased, the tree or plant shall be replaced by the owner with plant material meeting the requirements of this section.
 - 2. All buffer areas required as part of a development plan, whether in common or private ownership, shall be the responsibility of that development's property owners' association. Where there is no property owners' association, such landscaped areas shall be the responsibility of the property owner.
 - 3. Trees on developed properties may be pruned to maintain shape and promote their shade-giving qualities. They should be pruned to remove diseased or dying portions in areas where falling limbs could be a hazard to people or property. Lower limbs may be removed to provide

clearance. In addition, trees located in association with vehicular use areas shall also be pruned to allow a seven-foot clearance from ground level to avoid potential for damage or injury to pedestrians and cleared to thirteen (13) above pavement level for vehicles. However, the excessive pruning or pollarding of trees into round balls of crown or branches resulting in an unnecessary reduction of shade is prohibited and may require supplemental plantings. All pruning shall be done following the American National Standard for Tree Care Operations "Tree, Shrub and Other Woody Plant Maintenance - Standard Practices."

SECTION 3. CODIFICATION

It is the intent of the Board of County Commissioners that the provisions of this Ordinance shall be included and incorporated into the Land Development Code (LDC) of Nassau County, Florida. The codifier may re-letter or renumber sections to conform to the uniform numbering and style of the LDC.

SECTION 4. SEVERABILITY

It is the intent of the Board of County Commissioners of Nassau County, Florida, and is hereby provided, that if any section, subsection, sentence, clause, phrase, or provision of this Ordinance is held to be invalid or unconstitutional by any court of competent jurisdiction, such invalidity or unconstitutionality shall not be so construed as to render invalid or unconstitutional the remaining provisions of this Ordinance.

SECTION 5. EFFECTIVE DATE

This ordinance shall take effect upon filing with the Secretary of State as provided in Section 125.66, Florida Statutes.

ADOPTED THIS _____ DAY OF _____, 2018 BY THE BOARD OF COUNTY COMMISSIONERS OF NASSAU COUNTY, FLORIDA.

BOARD OF COUNTY COMMISSIONERS
NASSAU COUNTY, FLORIDA

Its: Chairman

ATTEST as to Chairman's Signature:

JOHN A. CRAWFORD
Its: Ex-Officio Clerk

Approved as to form

Michael S. Mullin,
County Attorney